

Jacketed pipe heat exchangers JP Pipe nominal diameter from 25 mm to 250 mm

Jacketed pipe heat exchangers

- Design: pressure: - 1 bar to + 10 bar inside and jacket.
- Design temperature: - 25°C to + 200°C.
- Construction according to PED Directive 97/23/CE.
- Glass lined nozzles with split loose flanges. Flanges PN 10 to EN 1092-1.
- PTFE envelope gasket on all assembled joints.
- Blue glass without plugs, tested to DIN 28063.
- Support by lugs.

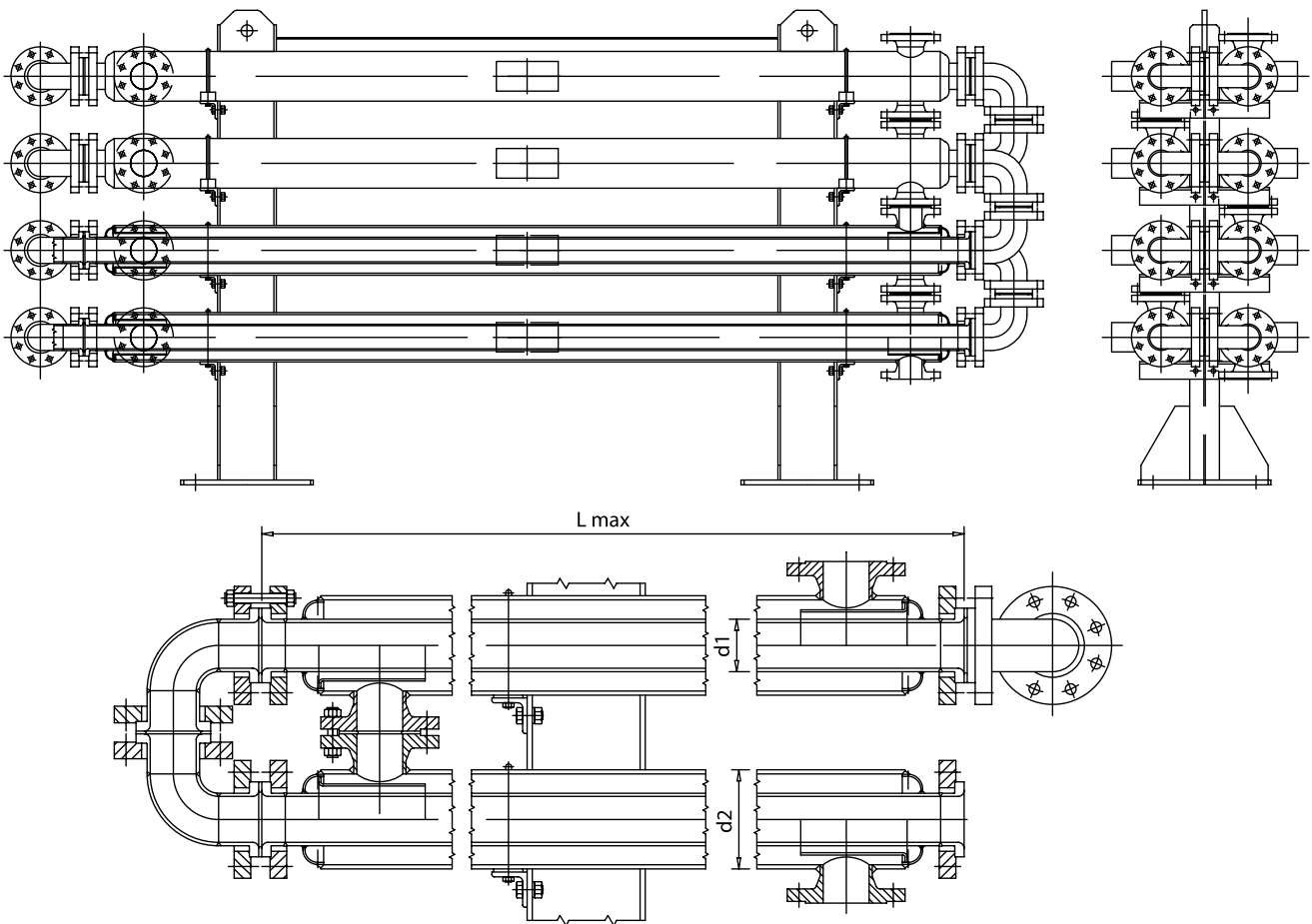

		Nominal size	DN	25	40	50	80	100	150	200	250
Dimensions	d1	mm	33,7	48,3	60,3	88,9	114,3	168,3	219,1	273,0	
	d2	mm	76,1	88,9	101,6	152,4	177,8	244,5	298,5	355,6	
	L max	mm	2.000	3.000	3.000	3.000	3.000	3.000	3.000	3.000	3.000
Exchange area for Lmax	S/Lmax	m ²	0,19	0,43	0,54	0,78	1,00	1,48	1,92	2,40	
Inner cross section	A	cm ²	4,3	11	19	44	77	180	315	497	
Weight per pipe	w	kg	27	61	73	134	175	270	390	505	

Shell and tube heat exchangers SF with tubes in SiC

- Design: pressure: - 1 bar to + 6 bar inside and jacket.
- Design temperature: - 25°C to + 200°C.
- Construction according to PED Directive 97/23/CE.
- Glass lined nozzles with split loose flanges.
- Flanges PN 10 to EN 1092-1.
- PTFE envelope gasket on all assembled joints.
- Blue glass without plugs, tested to DIN 28063.
- Support by saddles.



3V Glasscoat shell and tube heat exchangers can be of three different types:

1. Type SFA has the shell and shell-side tubesheets entirely glass-lined, the baffles are made of PTFE, the tubes of silicon carbide and the tube side is made of stainless steel. The product is introduced into the jacket side, the tube side is supplied with service fluid.

2. Type SFB has the shell and shell-side tubesheets made of stainless steel, the baffles are made of PTFE, the tubes of silicon carbide and the distributors on the tube side are entirely glass-lined. The service fluid is introduced into the shell side, the tube side is supplied with the product.

3. Type SFC has both shell side and tube side entirely glass-lined, the baffles are made of PTFE, the tubes of silicon carbide. Therefore two corrosive products can be treated, by introducing one into the shell side and the other into the tube side.

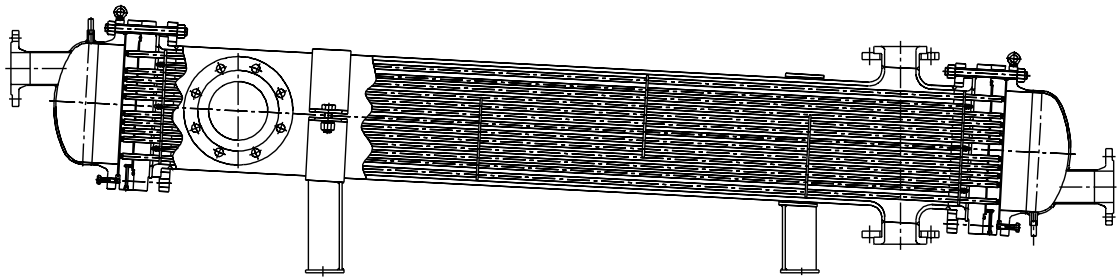

1. SFA

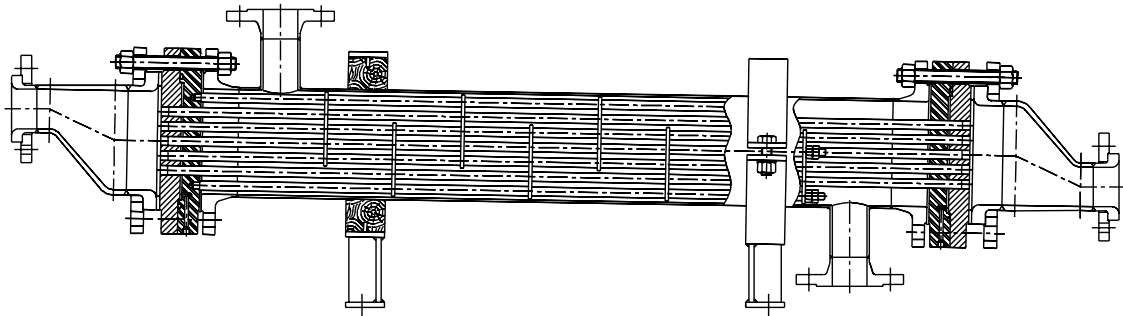

1. SFB

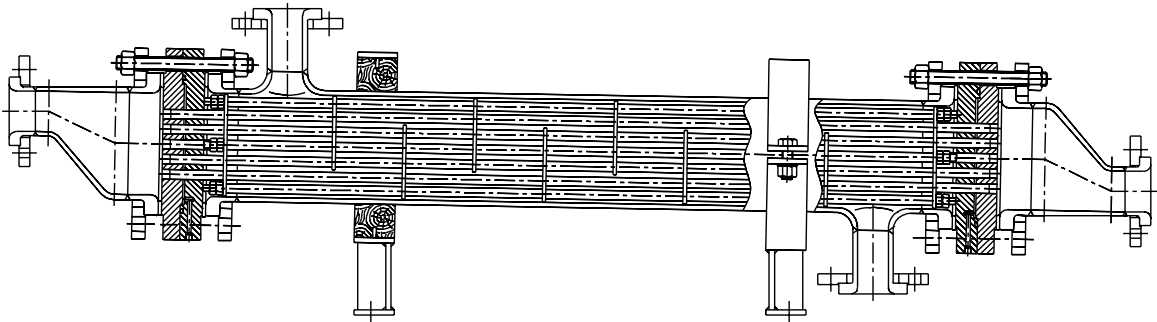

1. SFC

The tubesheets is double with an internal separation space which avoid direct contact between the fluids of two side in case of sealing failure.

The sealing tube-tubesheets is done by a-rings in perfluoroelastomero and in Viton.

The space is equipped with a drainage hole in the lower part to enable a visual check for the presence of leaks, but it can also be pressurised or connected to an automatic control system when particularly dangerous products are being used.

The tubes are made of Hexoloy SA silicon carbide by Saint-Gobain Ceramics.

- They are approved for use by: WRC, Water Byelaws Scheme (UK), DVGW Ministry of Health (D), FDA (USA).
- They have high thermal conductivity, double that of tantalum, 5 times that of stainless steel, 10 times that of Hastelloy and 15 times that of glass.
- Silicon carbide has an excellent resistance to corrosion with practically all chemical substances up to 200°C.
- Silicon carbide has very high hardness - 50% greater than tungsten carbide, and it is therefore extremely resistant to wear. It is also completely impervious and therefore offers total impermeability.

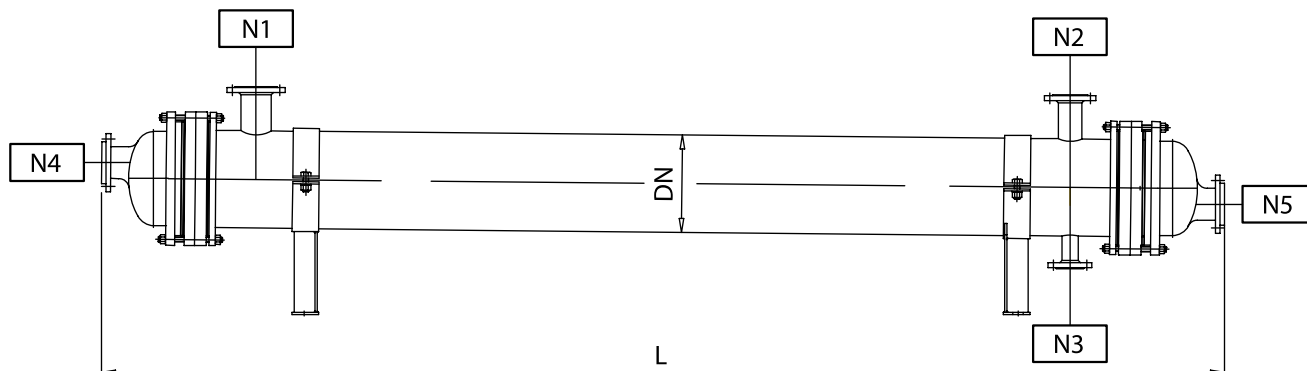

Nominal size	Pipe length	Number of pipes	Exchange area	Total length	N1 - N2	N3	N4 - N5
	mm	-	m ²	mm	DN	DN	DN
DN 100	1.000	-	0,35	1.400			
	1.500	8	0,53	1.900	50	25	40
	2.000		0,70	2.400			
DN 150	1.000		0,97	1.480			
	1.500	22	1,45	1.980	100	50	40
	2.000		1,94	2.480			
DN 200	1.000		1,85	1.540			
	1.500	42	2,77	2.040	150	50	50
	2.000		3,69	2.540			
	3.000		5,54	3.540			
DN 250	1.000		2,81	1.580			
	1.500	64	4,22	2.080	200	50	80
	2.000		5,63	2.580			
	3.000		8,44	3.580			
DN 300	1.500		6,33	2.100			
	2.000	96	8,44	2.600	250	80	80
	3.000		12,66	3.600			
DN 350	1.500		7,98	2.140			
	2.000	121	10,64	2.640	250	80	100
	3.000		15,96	3.640			
DN 400	2.000		14,33	2.720			
	3.000	163	21,50	3.720	300	100	100
DN 450	2.000		18,56	2.800			
	3.000	211	27,84	3.800	350	100	150
DN 500	2.000		23,39	2.880			
	3.000	266	35,09	3.880	400	100	200
DN 600	2.000		37,03	2.960			
	3.000	421	56	3.960	450	100	200

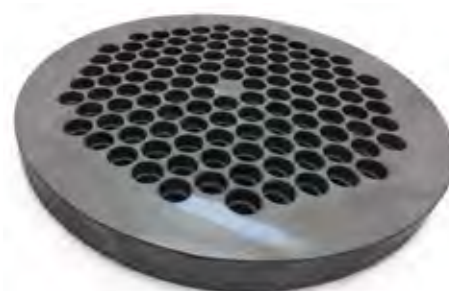
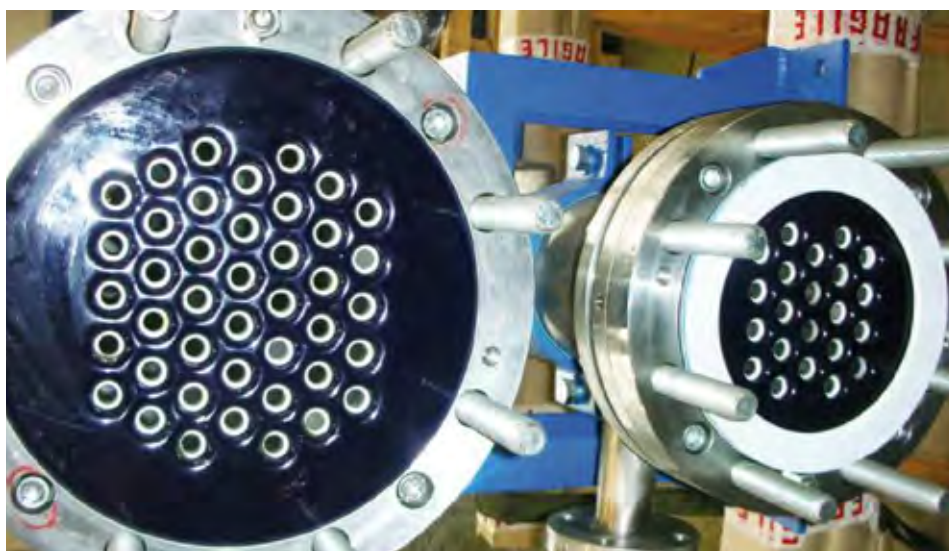

New solution with SiC plate