

Filter dryer – Filtrodry FEP/XD

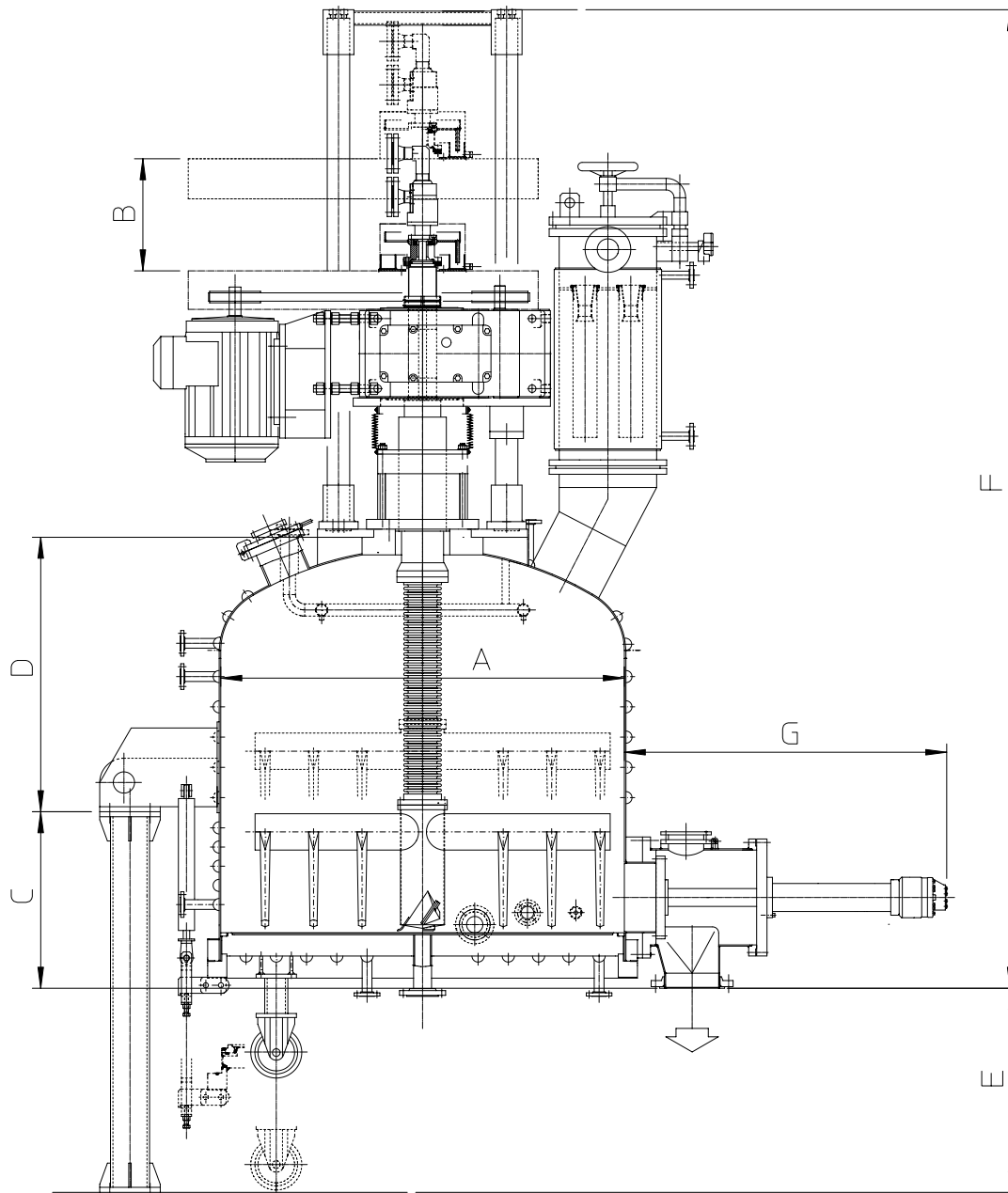

Model	Filtering surface	Product volume	Weight	A	B	C	D	E	F	G
	m ²	m ³	kg	mm	mm	mm	mm	mm	mm	mm
FEP/XD 050	0,5	0,61	-3.460	800	300	740	750	900	3.315	1.250
FEP/XD 100	1,13	1,71	-6.490	1.200	400	975	1.220	1.000	4.265	1.630
FEP/XD 150	1,53	2,25	-8.650	1.400	400	975	1.220	1.000	4.285	1.630
FEP/XD 200	2	2,93	-10.370	1.600	400	975	1.225	1.050	4.340	1.630
FEP/XD 250	2,54	3,58	-11.900	1.800	400	1.025	1.205	1.100	4.425	1.630
FEP/XD 300	3,14	4,51	-12.540	2.000	400	1.025	1.240	1.150	4.625	1.630
FEP/XD 400	4,15	5,42	-14.650	2.300	400	1.055	1.400	1.150	4.830	1.630
FEP/XD 500	5,3	9,19	-15.750	2.600	500	1.145	1.670	1.350	5.495	1.630
FEP/XD 600	6,15	10,35	-22.440	2.800	500	1.165	1.680	1.400	5.565	1.630
FEP/XD 800	8	13,03	-23.620	3.200	500	1.285	1.600	1.500	5.687	1.630
FEP/XD 1.000	10,17	15,37	-33.180	3.600	500	1.335	1.600	1.500	5.827	1.630
FEP/XD 1.200	12,56	12,6	-36.590	4.000	500	1.355	1.600	1.500	5.850	1.630