

Filter dryer - Filtrodry FEP/TD

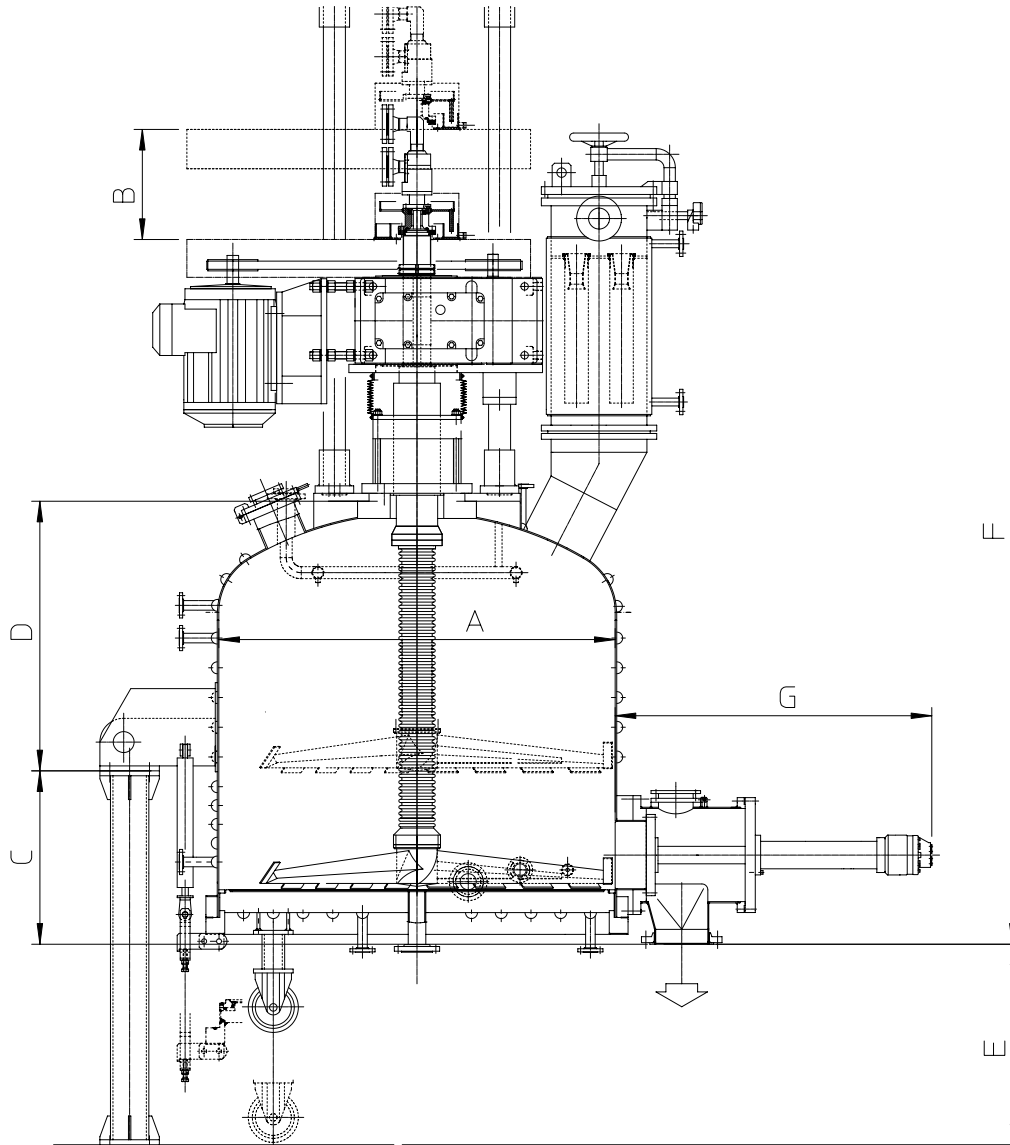

Model	Filtering surface	Product volume	Weight	A	B	C	D	E	F	G
	m ²	m ³	kg	mm	mm	mm	mm	mm	mm	mm
FEP/TD 050	0,5	0,48	-3.295	800	300	540	950	900	3.320	1.250
FEP/TD 100	1,13	1,29	-6.180	1.200	400	725	1.085	970	3.860	1.630
FEP/TD 150	1,53	1,68	-8.240	1.400	400	725	1.085	970	3.880	1.630
FEP/TD 200	2	2,14	-9.880	1.600	400	725	1.110	1.040	3.970	1.630
FEP/TD 250	2,54	2,58	-11.330	1.800	400	725	1.110	1.100	4.030	1.630
FEP/TD 300	3,14	3,28	-11.950	2.000	400	725	1.190	1.080	4.250	1.630
FEP/TD 400	4,15	3,93	-13.950	2.300	400	725	1.220	1.110	4.290	1.630
FEP/TD 500	5,3	6,58	-15.000	2.600	500	825	1.500	1.310	4.900	1.630
FEP/TD 600	6,15	7,39	-21.370	2.800	500	825	1.510	1.350	5.000	1.630
FEP/TD 800	8	9,17	-22.500	3.200	500	825	1.550	1.430	5.090	1.630
FEP/TD 1.000	10,17	10,79	-31.600	3.600	500	825	1.580	1.430	5.120	1.630
FEP/TD 1.200	12,56	12,6	-34.850	4.000	500	825	1.600	1.450	5.040	1.630